

# ***IIDAS®* AMUSEMENT & VIDEO SYSTEM 102DA/KA (MODEL 1020)**

## **SENSITIVITY DESCRIPTION**

The *IIDAS®* impact/abuse sensor is designed to detect severe impact, unwarranted abuse, or abrupt rocking. After installation, if it is necessary to adjust the impact sensitivity, remove the sensor window (see Fig. 1) from the *IIDAS®* Controller, and with a small flat-head screwdriver simply turn the screw, in one-half turn steps, clockwise to increase the impact sensitivity and counter-clockwise to decrease the impact sensitivity. Whenever the impact/abuse sensor is triggered *IIDAS®* will instantly alarm for approximately 30 seconds and then reset automatically. The alarm output may be shortened or lengthened at BRW's factory. Whenever *IIDAS®* is triggered again, during an alarm cycle, it will restart its 30 second alarm output. Whenever *IIDAS®* is triggered by a door being illicitly opened it will instantly alarm for approximately 30 seconds and then reset automatically.

## **INSTALLATION INSTRUCTIONS**

***IIDAS®* CONTROLLER:** Remove the two-sided tape backing from the *IIDAS®* Controller and attach it to a clean surface on the inside of the coin amusement or video game with the *IIDAS®* LED facing upwards (see Fig. 2). For best performance attach near the lock assembly.

**BATTERY PACK:** Remove the two-sided tape backing from the battery pack and attach to a clean solid surface within wire length of the *IIDAS®* Controller (see Fig. 2).

**SIREN:** Remove the two-sided tape backing from the siren and attach to a clean surface inside the coin amusement or video game (see Fig. 2). Use the siren's mounting bracket if possible.

**RESET SWITCH (System 102DA):** The magnetic contact assembly is used to disarm *IIDAS®* when the service door is opened. Remove the two-sided tape backing from the switch portion of the magnetic contact assembly and attach it to the flat mounting bracket as shown in Fig. 2. Then attach the bracket with the switch to the inside wall facing outwards towards the door's opening (see Fig. 2). Attach the magnet portion to the door frame, parallel to the switch. The maximum gap between the switch and the magnet should be no more than ½ inch. Use the spacer or the plastic "L" bracket if necessary. Check installation with a meter to insure proper alignment (Door Open = closed, Door Closed = open). (Use plastic spacers to raise the magnet if necessary).

**RESET SWITCH (System 102KA):** With this model a key lock is used to disarm *IIDAS®* before the coin amusement or video game is serviced. Drill a .750 diameter hole and mount the switch (see Fig. 4). Prior to service the key lock must be activated to disarm *IIDAS®*.

**DOOR TRIGGER:** For the Cash Door, remove the two-sided tape backing from the switch portion of the magnetic contact assembly, and locate a convenient space on the cash door opening to attach the switch. (See Fig. 2B). Attach the magnet portion to the inside of the cash door parallel to the switch. (See Fig. 2B). Check alignment. For the Rear Door, attach the switch portion to the inside wall of the Rear Door Access, and then attach the magnet portion to the inside of the rear door parallel to the switch. (See Fig. 3). Check alignment.

## **WIRING INSTRUCTIONS**

**NOTE: DO NOT CONNECT THE POWER SOURCE UNTIL ALL WIRING IS COMPLETE.**

**RED WIRE (Battery +):** Attach the red wire on the *IIDAS®* Controller to the red wire on the battery pack connector (socket side) or to a power supply (+) terminal. 15 volts DC maximum.

**BLACK WIRE (Battery -):** Attach the black wire on the *IIDAS®* Controller to the black wire on the battery pack connector (socket side) or to a power supply (-) terminal.

**WHITE WIRE (Reset):** For *System 102DA*, attach the white wire on the *IIDAS®* Controller to either one of the wires on the switch portion of the magnetic contact assembly. Attach the other wire of the switch portion to the black wire (-) on the battery (see Fig. 1 & 3). For *System 102KA*, attach the white wire on the *IIDAS®* Controller to the white wire on the key lock, then attach the black wire on the key lock to the black wire (-) on the battery (see Fig. 1 & 4).

**GREEN WIRE (Door Trigger):** Attach the green wire on the *IIDAS®* Controller to either one of the wires on the switch portion of the magnetic contact assembly. Attach the other wire of the switch portion to the black (-) wire of the battery pack connector (socket side). (See Fig. 1 & 3). Repeat this wiring for additional doors.

**ORANGE WIRE (Alarm Output):** Attach the orange wire of the *IIDAS®* Controller to the black wire on the siren. Then attach the red wire on the siren to the red wire on the battery (see Fig. 1).

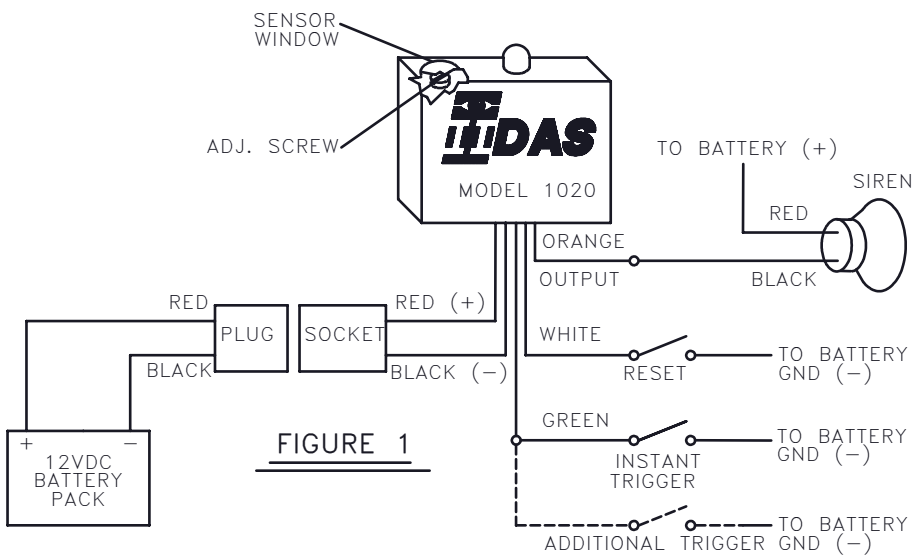

**FIGURE 1**

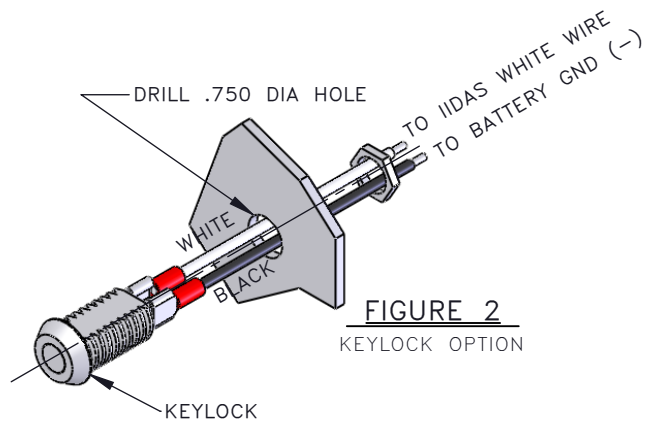

**FIGURE 2**  
KEYLOCK OPTION

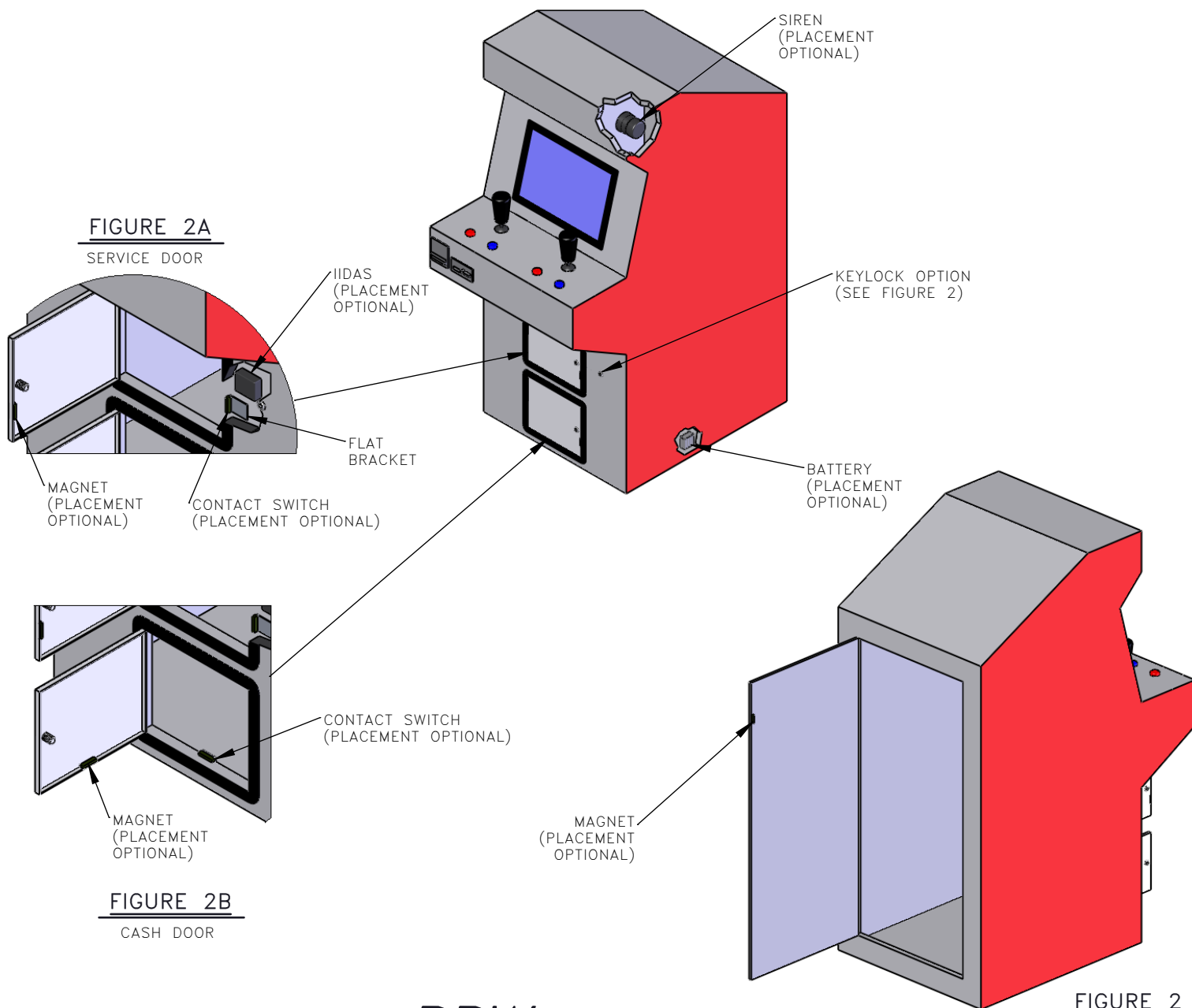

**BRW** Control Systems Inc.

1747 E. Ave Q. Ste E-5 Palmdale, CA 93550 (800) 235-6740  
E-Mail: sales@brwcontrol.com Internet: www.brwcontrol.com