

# ***IIDAS*® CURRENCY & COIN CHANGER SYSTEM 1050 (MAXIMUM)**

## **SENSITIVITY DESCRIPTION**

The *IIDAS*® impact/abuse sensor is designed to detect severe impact, unwarranted abuse, or abrupt rocking. After installation, if it is necessary to adjust the impact sensitivity, remove the sensor window (see Fig. 1) from the *IIDAS*® Controller, and with a small flat-head screwdriver simply turn the screw, in one-half turn steps, clockwise to increase the impact sensitivity and counter-clockwise to decrease the impact sensitivity. Whenever the impact/abuse sensor is triggered *IIDAS*® will instantly alarm for approximately 30 seconds and then reset automatically. The alarm output may be shortened or lengthened at BRW's factory. Whenever *IIDAS*® is triggered again, during an alarm cycle, it will restart its 30 second alarm output. Whenever *IIDAS*® is triggered by a door being illicitly opened it will instantly alarm for approximately 30 seconds and then reset automatically.

## **INSTALLATION INSTRUCTIONS**

***IIDAS*® CONTROLLER:** Remove the two-sided tape backing from the *IIDAS*® Controller and attach it to a clean surface on the inside of the changer machine, near the area likely to be attacked, with the *IIDAS*® LED facing upwards (see Fig. 2). For best performance, if the service door is accessible, attach near the lock assembly.

**BATTERY PACK:** Remove the two-sided tape backing from the battery pack and attach to a clean solid surface within wire length of the *IIDAS*® Controller.

**SIREN:** Remove the two-sided tape backing from the siren and attach to a clean surface on the inside of the changer machine door if space permits (see Fig. 2). Use the siren's mounting bracket if possible.

**RESET SWITCH:** Remove the two-sided tape backing from the reset switch assembly and attach it inconspicuously inside the changer machine's service door. The reset switch should be placed out-of-sight, but within immediate reach of the person servicing the changer machine. (See Fig. 2).

**MAGNETIC CONTACT ASSEMBLY (*Door Delay Trigger*):** Remove the two-sided tape backing from the switch portion of the magnetic contact assembly. Locate a convenient space on the inside of the service door, and attach the switch. Remove the two-sided tape backing from the magnet portion and attach it inside the changer machine, parallel to the switch. The maximum gap between the switch and the magnet should be no more than ½ inch. Use the spacer or the plastic "L" bracket if necessary. Check installation with a meter to insure proper alignment (Door Open = closed, Door Closed = open). (See Fig. 2).

**MAGNETIC CONTACT ASSEMBLY (*Instant Trigger*):** If you are using the *Door Delay Trigger* input for the service door, the instant trigger connection will not be used. However, if this connection is used, attach the magnetic contact assembly in the same manner as the *Door Delay Trigger*.

## **WIRING INSTRUCTIONS**

**NOTE: DO NOT CONNECT THE POWER SOURCE UNTIL ALL WIRING IS COMPLETE.**

**RED WIRE (*Battery +*):** Attach the red wire on the *IIDAS*® Controller to the red wire on the battery pack connector (socket side) or to a power supply (+) terminal. 15 volts DC maximum.

**BLACK WIRE (*Battery -*):** Attach the black wire on the *IIDAS*® Controller to the black wire on the battery pack connector (socket side) or to a power supply (-) terminal.

**WHITE WIRE (*Reset*):** Attach the white wire on the *IIDAS*® Controller to the white wire on the reset switch. Attach the red wire on the reset switch to the red wire (+) on the battery pack connector (socket side).

**BLUE WIRE (*Delay Trigger*):** Attach the blue wire on the *IIDAS*® Controller to either one of the wires on the switch portion of the magnetic contact assembly. Attach the other wire of the switch portion to the black wire (-) on the battery pack connector (socket side). (Delay Time = 5 seconds).

**GREEN WIRE (*Instant Trigger - Optional for Second Door*):** Attach the green wire on the *IIDAS*® Controller to either one of the wires on the switch portion of the magnetic contact assembly. Attach the other wire of the switch portion to the black (-) wire of the battery pack connector (socket side).

**ORANGE WIRE (*Alarm Output*):** Attach the orange wire of the *IIDAS*® Controller to the black wire on the siren. Then attach the red wire on the siren to the red wire on the battery (see Fig. 1).

**After connecting power, immediately push the reset button and close all doors. The system will arm in two seconds, followed by a "chirp" sound.**

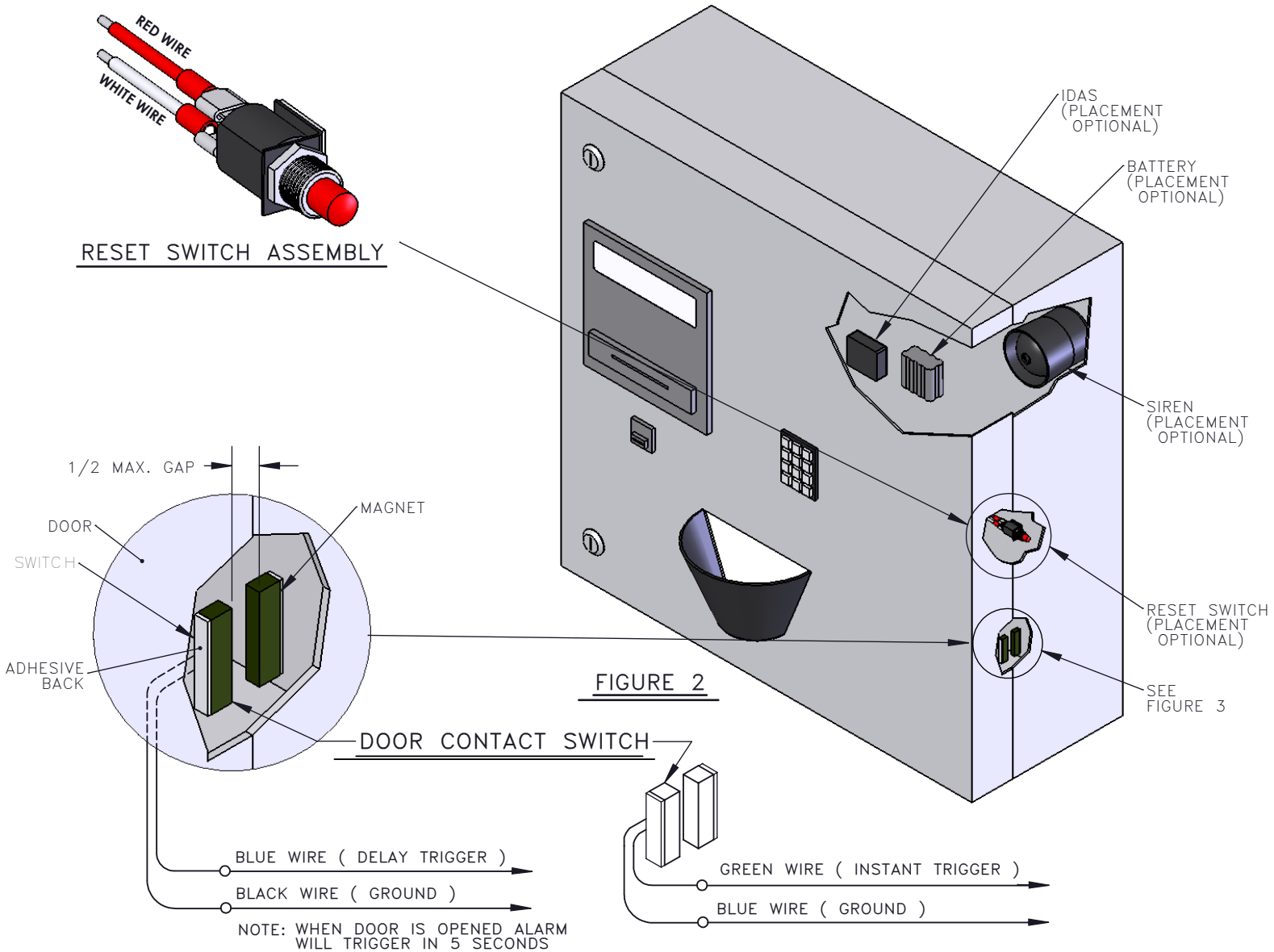
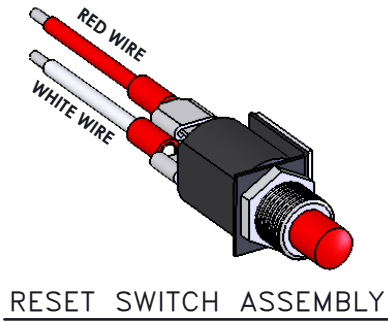
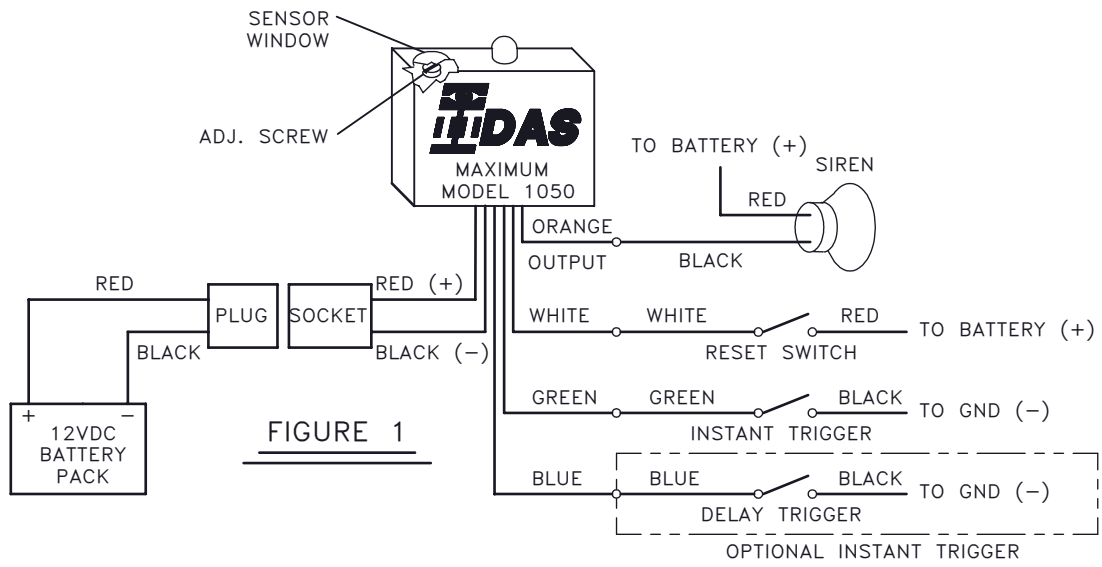

**FIGURE 3**

**BRW** Control Systems Inc.

1747 E. Ave Q. Ste E-5 Palmdale, CA 93550 (800) 235-6740  
E-Mail: sales@brwcontrol.com Internet: www.brwcontrol.com