

# ***IIDAS®* LOTTERY SYSTEM 105DA/KA (MODEL 1020)**

## **SENSITIVITY DESCRIPTION**

The ***IIDAS®*** impact/abuse sensor is designed to detect severe impact, unwarranted abuse, or abrupt rocking. After installation, if it is necessary to adjust the impact sensitivity, remove the sensor window (see Fig. 1) from the ***IIDAS®* Controller**, and with a small flat-head screwdriver simply turn the screw, in one-half turn steps, clockwise to increase the impact sensitivity and counter-clockwise to decrease the impact sensitivity. Whenever the impact/abuse sensor is triggered ***IIDAS®*** will instantly alarm for approximately 30 seconds and then reset automatically. The alarm output may be shortened or lengthened at BRW's factory. Whenever ***IIDAS®*** is triggered again, during an alarm cycle, it will restart its 30 second alarm output. Whenever ***IIDAS®*** is triggered by a door being illicitly opened it will instantly alarm for approximately 30 seconds and then reset automatically.

## **INSTALLATION INSTRUCTIONS**

***IIDAS®* CONTROLLER:** Remove the two-sided tape backing from the ***IIDAS®* Controller** and attach it to a clean surface on the inside the lottery machine's door with the ***IIDAS®* LED** facing upwards (see Fig. 2). For best performance attach near the lock assembly.

**BATTERY PACK:** Remove the two-sided tape backing from the battery pack and attach to a clean solid surface within wire length of the ***IIDAS®* Controller**.

**SIREN:** Remove the two-sided tape backing from the siren and attach to a clean surface on the inside of the lottery machine (see Fig. 2). Use the siren's mounting bracket if possible.

**RESET SWITCH (System 105DA):** The magnetic contact assembly is used to disarm ***IIDAS®*** when the service door is opened. Remove the two-sided tape backing and locate a space on the inside of the lottery machine's door and attach the switch portion; then attach the magnet portion inside the lottery machine, on the door's frame, parallel to the switch. The maximum gap between the switch and the magnet should be no more than ½ inch. Use the spacer or the plastic "L" bracket if necessary. Check installation with a meter to insure proper alignment (Door Open = closed, Door Closed = open). (See Fig. 2).

**RESET SWITCH (System 105KA):** With this model a key lock is used to disarm ***IIDAS®*** before the lottery machine is serviced. Drill a .750 diameter hole and mount the switch. Prior to service the key lock must be activated to disarm ***IIDAS®***.

**DOOR TRIGGER:** Attach the magnetic contact assembly in the same manner as the reset switch on *System 103DA* above.

## **WIRING INSTRUCTIONS**

**NOTE: DO NOT CONNECT THE POWER SOURCE UNTIL ALL WIRING IS COMPLETE.**

**RED WIRE (Battery +):** Attach the red wire on the ***IIDAS®* Controller** to the red wire on the battery pack connector (socket side) or to a power supply (+) terminal. 15 volts DC maximum.

**BLACK WIRE (Battery -):** Attach the black wire on the ***IIDAS®* Controller** to the black wire on the battery pack connector (socket side) or to a power supply (-) terminal.

**WHITE WIRE (Reset):** For *System 105DA*, attach the white wire on the ***IIDAS®* Controller** to either one of the wires on the switch portion of the magnetic contact assembly. Attach the other wire of the switch portion to the black wire (-) on the battery (see Fig. 2). For *System 105KA*, attach the white wire on the ***IIDAS®* Controller** to the white wire on the key lock, then attach the black wire on the key lock to the black wire (-) on the battery (see Fig. 1 & 4).

**GREEN WIRE (Door Trigger):** Attach the green wire on the ***IIDAS®* Controller** to either one of the wires on the switch portion of the magnetic contact assembly. Attach the other wire of the switch portion to the black (-) wire of the battery pack connector (socket side). (See Optional Instant Trigger).

**ORANGE WIRE (Alarm Output):** Attach the orange wire of the ***IIDAS®* Controller** to the black wire on the siren. Then attach the red wire on the siren to the red wire on the battery (see Fig. 1).

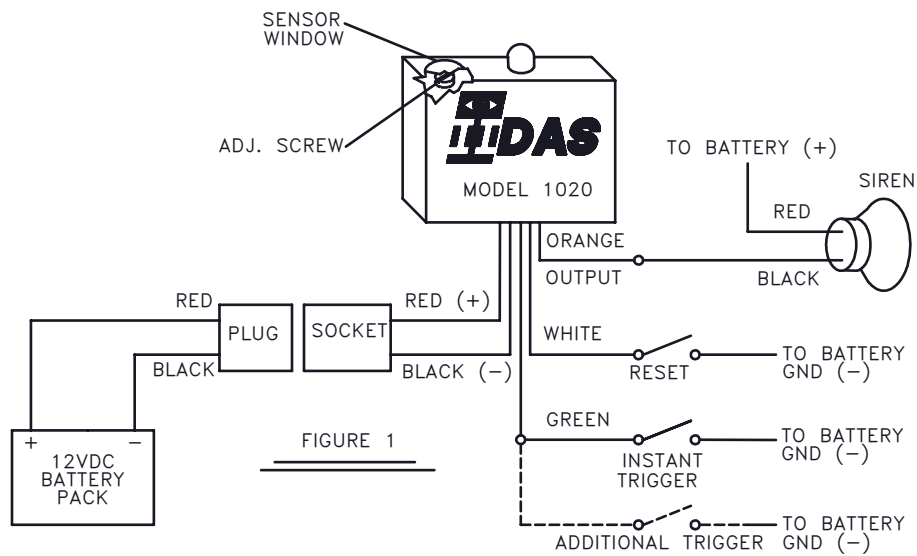

FIGURE 1

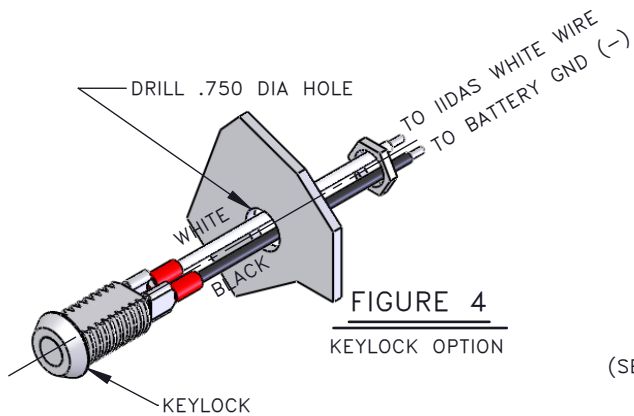

FIGURE 4

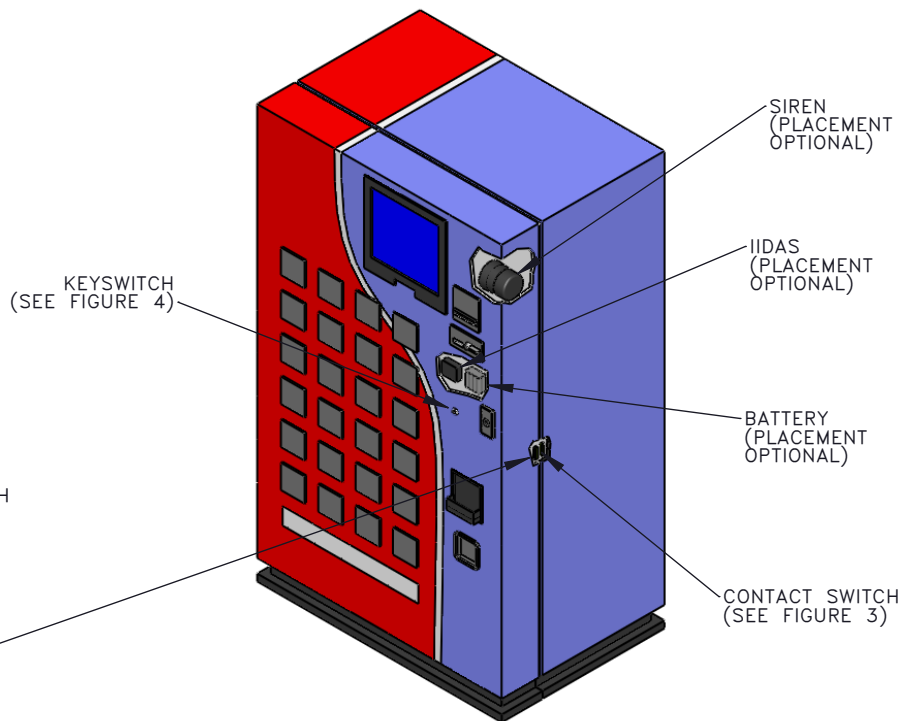

FIGURE 2

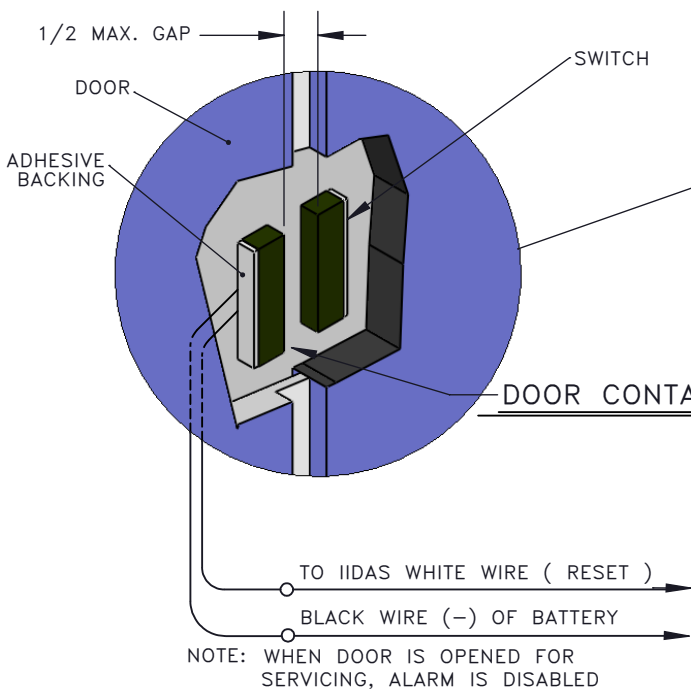
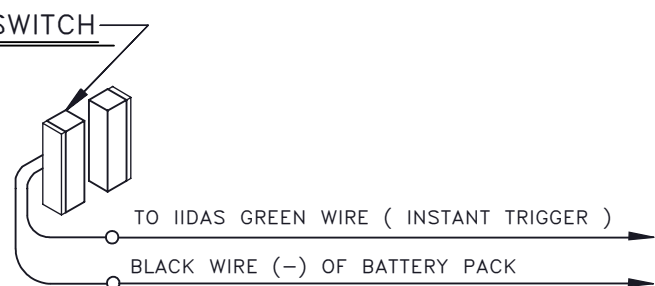

FIGURE 3



OPTIONAL INSTANT TRIGGER

**BRW** Control Systems Inc.

1747 E. Ave Q. Ste E-5 Palmdale, CA 93550 (800) 235-6740  
E-Mail: sales@brwcontrol.com Internet: www.brwcontrol.com